



CONVERSION HOISTS

VC416(SF)/VC516(SF)

For Standard cab and chassis with platform and dump bodies.

- *For 8' –12' bodies.*
- *Capacities up to 15 tons.*
- *Available with 4" or 5" cylinder and 16" stroke.*
- *Low mounting height scissors design with Narrow drop hinge knuckle.*
- *Pre-installed self-locating body prop.*
- *Choice of pumps:*
 - Electric single acting*
 - Electric double acting*
 - 4 Piston PTO*
 - Direct mount PTO*
- *Fits 29 ½" – 34" truck frames.*
- *Unitized quick mount hinge assembly.*
- *Completely assembled at factory to eliminate parts shortages and speed installation.*
- *All hoses, fittings, wiring and controls included.*

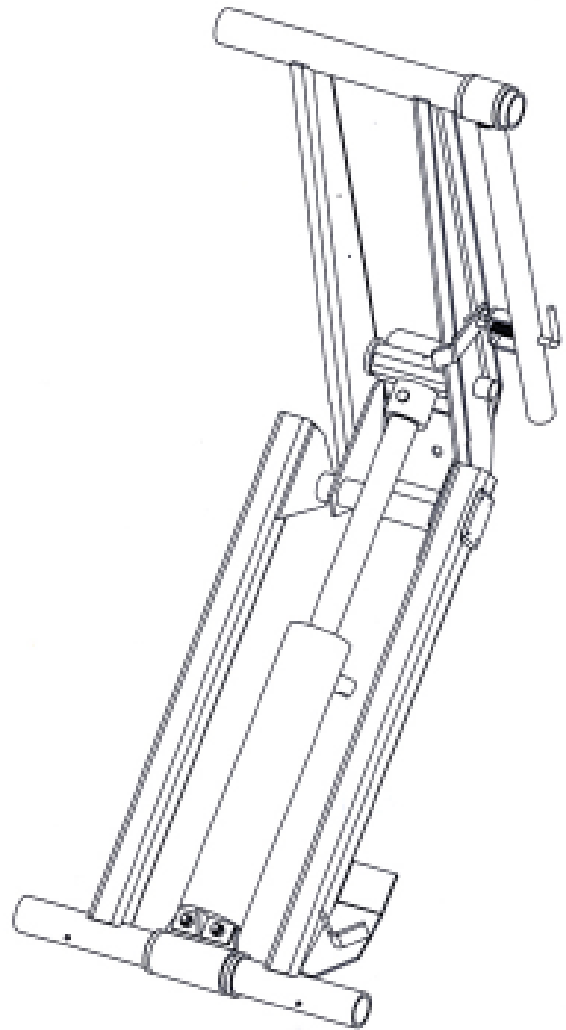

AVAILABLE WITH OPTIONAL SUBFRAME

- *34" frame width for 60" and 84" CA.*
- *45° or 50° dump angle.*
- *Power unit mounting bracket*
- *Fuel filler and frame hump knockouts.*
- *Tapered body guides.*
- *Factory installed hoist and hinge kit.*

SPECIFICATIONS

VC416

- Conversion class B
- Dump class 10
- High pressure double acting cylinder with 4" bore x 16" stroke and multi-hard chromed and polished piston rod.
- Mounting height 5 3/4"

- Pumps: Electric single acting, 6 qt. reservoir
Electric double acting, 4 qt. reservoir
4 piston PTO driven, 7/8" square shaft, 7 qt. reservoir
Direct mount gear PTO driven, SAE "A" 2 bolt flange,
5/8" -9 spline shaft 9 qt. reservoir

- Operating pressure: 3000/1000 PSI
- Weight: VC416 – 325 lbs.
VC416SF – 350 lbs.

VC516

- Conversion class C
- Dump class 20
- High pressure double acting cylinder with 5" bore x 16" stroke and multi-hard chromed and polished piston rod.
- Mounting height 5 3/4"

- Operating pressure: 3000/1000 PSI
- Weight: VC516 – 365 lbs.
VC516SF – 390 lbs.

Body Length	C/A	Rear Overhang	Capacity (tons) 45° Dump*	Capacity (tons) 50° Dump*
8'	60"	6"	6.9	6.4
9'	60"	18"	8.0	7.4
10'	60"	30"	9.7	8.8
10'	84"	6"	5.4	5.0
11'	84"	18"	6.0	5.6
11'	102"	0"	4.4	4.0
12'	84"	30"	6.9	6.3

Body Length	C/A	Rear Overhang	Capacity (tons) 45° Dump*	Capacity (tons) 50° Dump*
8'	60"	6"	10.8	10.0
9'	60"	18"	12.6	11.5
10'	60"	30"	15.1	13.8
10'	84"	6"	8.4	7.8
11'	84"	18"	9.4	8.7
11'	102"	0"	6.0	6.3
12'	84"	30"	10.8	9.8
12'	102"	12"	7.5	6.9
12'	108"	6"	6.8	6.3

ONE YEAR WARRANTY

This limited policy warrants new products of Venco to be free from defects in material and workmanship for a period of one (1) year from date of original installation. This warranty covers:

- ◆ Repair or replacement of product
- ◆ Labor to repair or replace product
- ◆ Freight to return and/or replace product

We shall not be liable for any contingent liabilities arising out of the improper function of any products. Warranty shall become void if the product is improperly installed, modified, damaged, abused or used for application other than intended use.

*CAPACITIES BASED ON WATER LEVEL LOAD, UNDIMINISHING, AND INCLUDES BODY WEIGHT.

CAUTION: THE COMBINED WEIGHTS OF TRUCK, BODY, HOIST AND LOAD MUST NOT EXCEED THE GROSS VEHICLE WEIGHT RATING (GVWR) OF THE TRUCK.

A Product of:



MANUFACTURING, INC.

12110 BEST PLACE
CINCINNATI, OHIO 45241
PHONE: (800)226-2238
FAX: (513)326-5427

www.venturo.com

Email: sales@venturo.com

Distributed By: